

**ELEVATION**

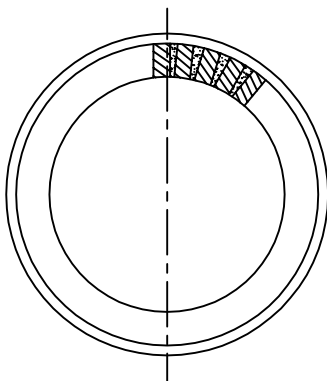

**DETAIL STANDARD MASONRY MANHOLES**  
NOT TO SCALE

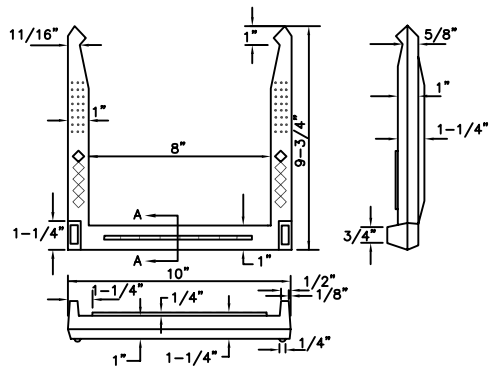

**POLYPROPYLENE PLASTIC**  
NO. 3 DEFORMED STEEL ROD

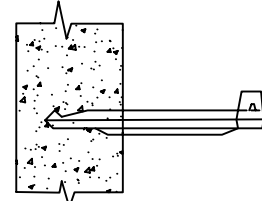
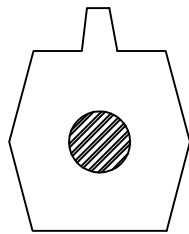

**PS-1 OR PS-3 MANHOLE STEP**  
NOT TO SCALE

SEE SHEET NO. 2 FOR GENERAL NOTES.

The City Of Eric  
401 West Owen K. Cornett Road  
Eric, Okla. 73832  
Telephone: (800) 234-0060 Fax: (800) 234-8946

**Contacts:**  
Robert Hitt, Director of Engineering Services, Est. 344  
James Brinkley, Civil Engineer, Est. 346



REVISIONS		
Number	Date	Description
1	10/19/94	Title Sheet
2	3/2/00	Specification Review Change

Project Number:	Project Location:
STANDARD MASONRY MANHOLES AND STEPS	DD - 1 SHT. 1
Sheet Title:	Project Title:



Date:	8/1/81
Scale:	NO SCALE
Cad File:	G:\DATA\SPRCS\001
Drawn By:	P.B.
Designed By:	R.H.
Approved By:	R.H.
Sheet:	of